

P19

TERREO - L1  
ESC 1:20

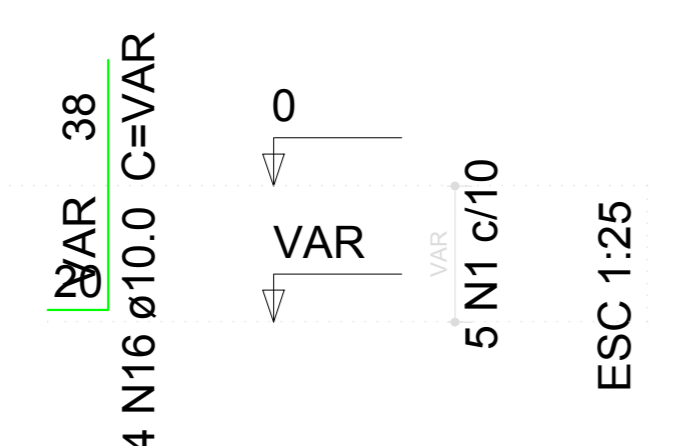
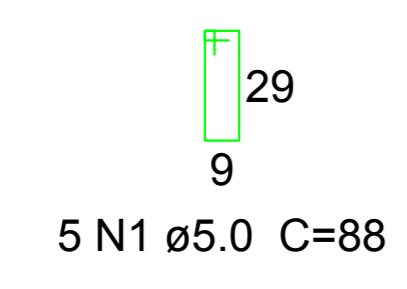
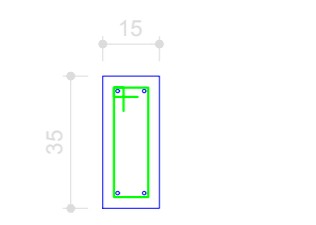

P9=P10=P13=P16=P18=P21=P22

TERREO - L1  
ESC 1:20

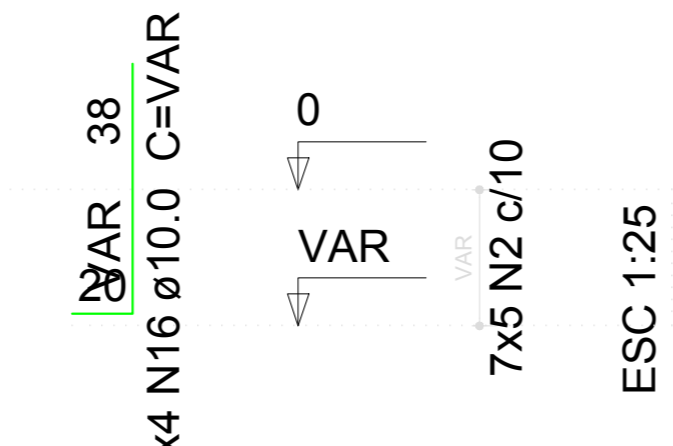
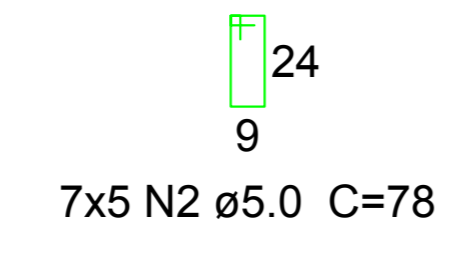
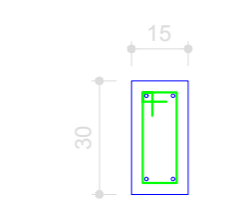

B9=B10=B13=B16=B18=B19=B21=B22

3xR20  
PLANTA  
ESC 1:25

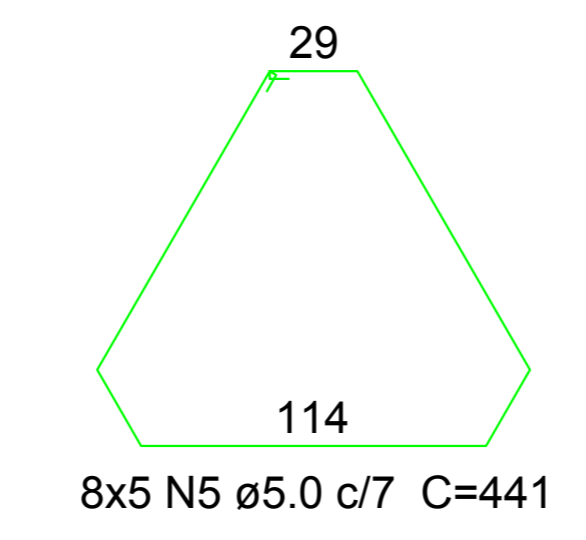
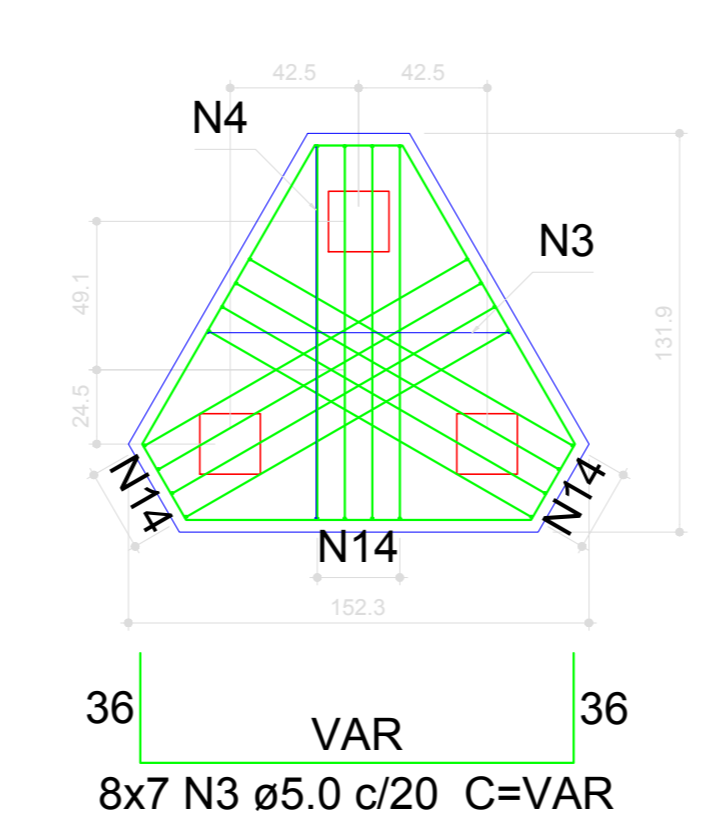

CORTE  
ESC 1:25

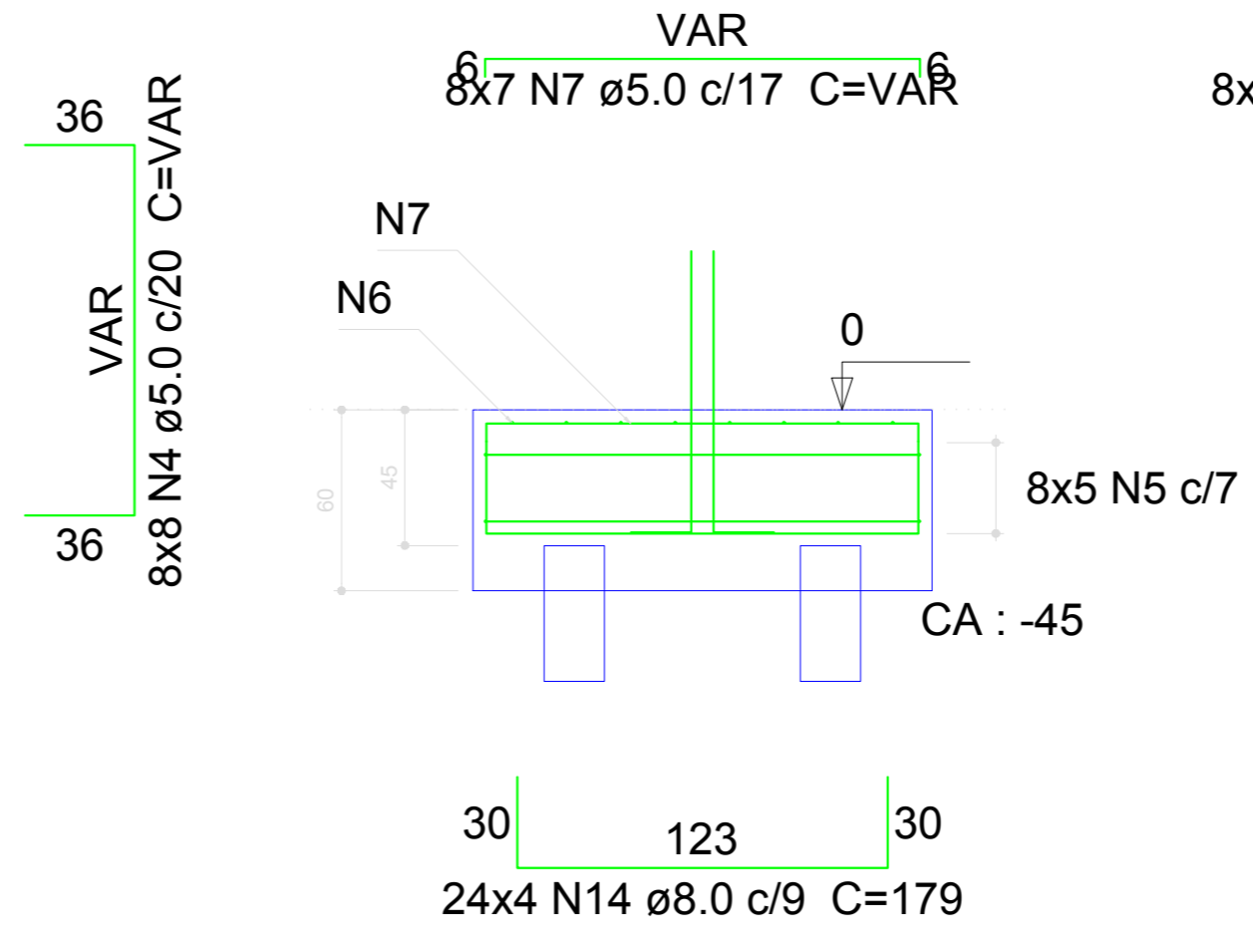

Relação do aço

AÇO	N	DIAM (mm)	QUANT (Barras)	B19		B25	
				UNIT (cm)	C.TOTAL (cm)	UNIT (cm)	C.TOTAL (cm)
CA60	1	5.0	5	88	440		
	2	5.0	83	78	6474		
	3	5.0	56	VAR	VAR		
	4	5.0	64	VAR	VAR		
	5	5.0	40	441	17640		
	6	5.0	64	VAR	VAR		
	7	5.0	56	VAR	VAR		
	8	5.0	3	24	72		
	9	5.0	6	88	528		
	10	5.0	36	143	5148		
	11	5.0	90	138	12420		
	12	5.0	90	300	27000		
	13	5.0	72	111	7992		
CA50	14	8.0	96	179	17184		
	15	8.0	72	141	10152		
	16	10.0	32	VAR	VAR		
	17	10.0	78	VAR	VAR		

Resumo do aço

AÇO	DIAM (mm)	C.TOTAL (m)	PESO + 10% (kg)
CA50	8.0	273.4	118.6
	10.0	99.4	67.4
CA60	5.0	1191.3	202
<b>PESO TOTAL (kg)</b>			
CA50		186.1	
CA60		202	

Volume de concreto (C-25) = 10.99 m³  
Área de forma = 56.06 m²

P11

TERREO - L1  
ESC 1:20

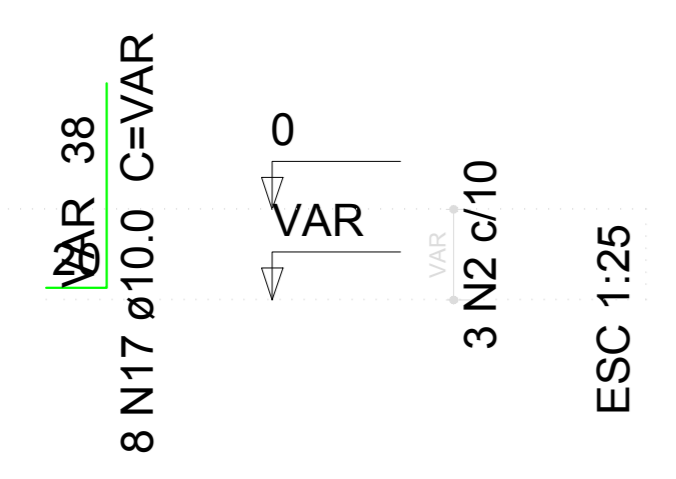
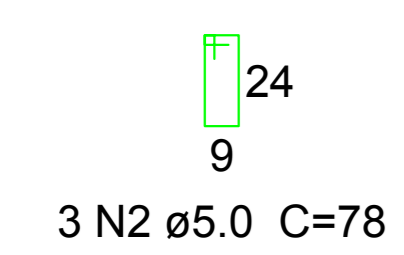
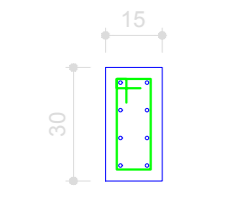

P12

TERREO - L1  
ESC 1:20

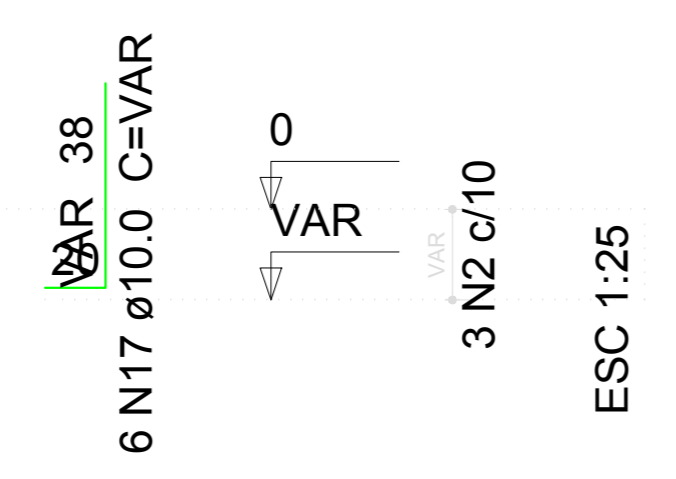
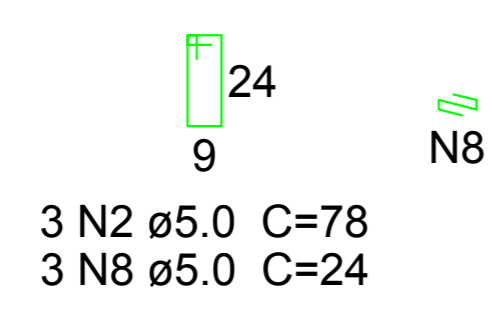
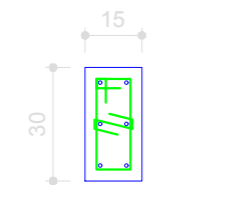

P24=P25

TERREO - L1  
ESC 1:20

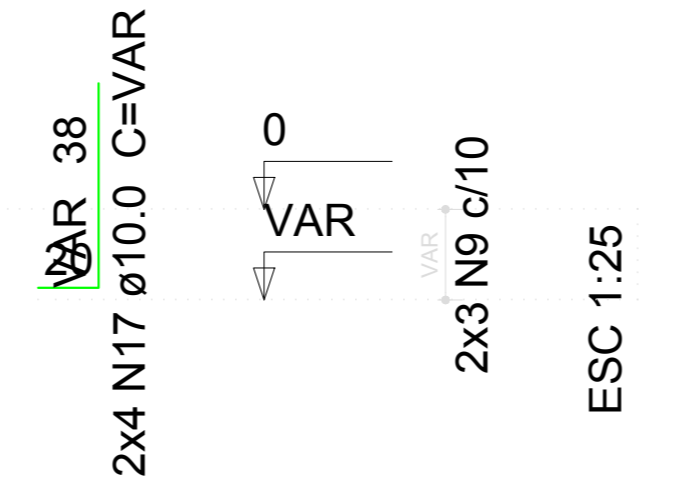
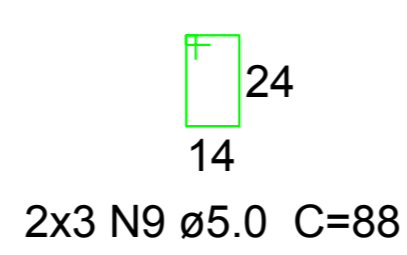
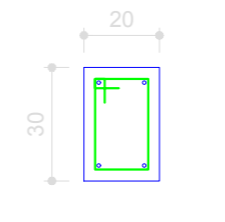

P1=P2=P3=P4=P5=P6=P7=P8=P14=P15=P17=P20=P23=P26

TERREO - L1  
ESC 1:20

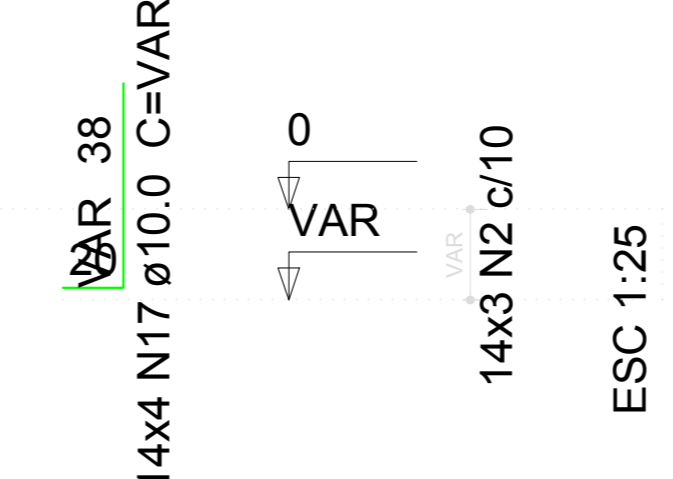
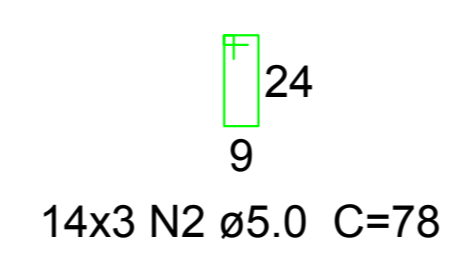
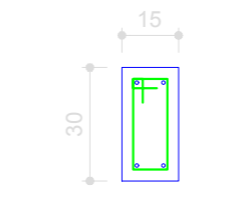

B1=B2=B3=B4=B5=B6=B7=B8=B11=B12=B14=B15=B17=B20=B23=B24=B25=B26

2xR20  
PLANTA  
ESC 1:25

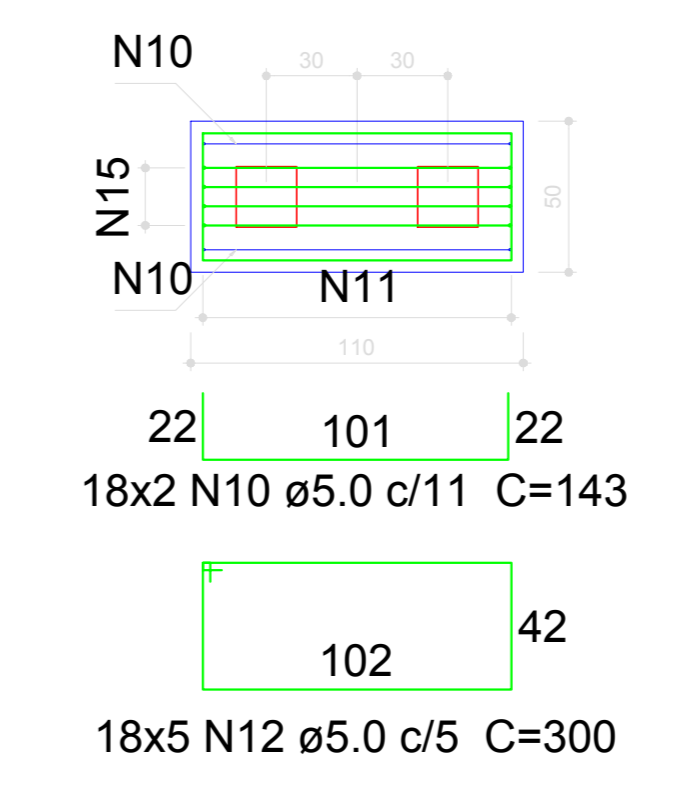

CORTE  
ESC 1:25

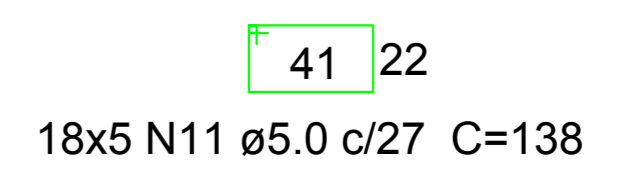
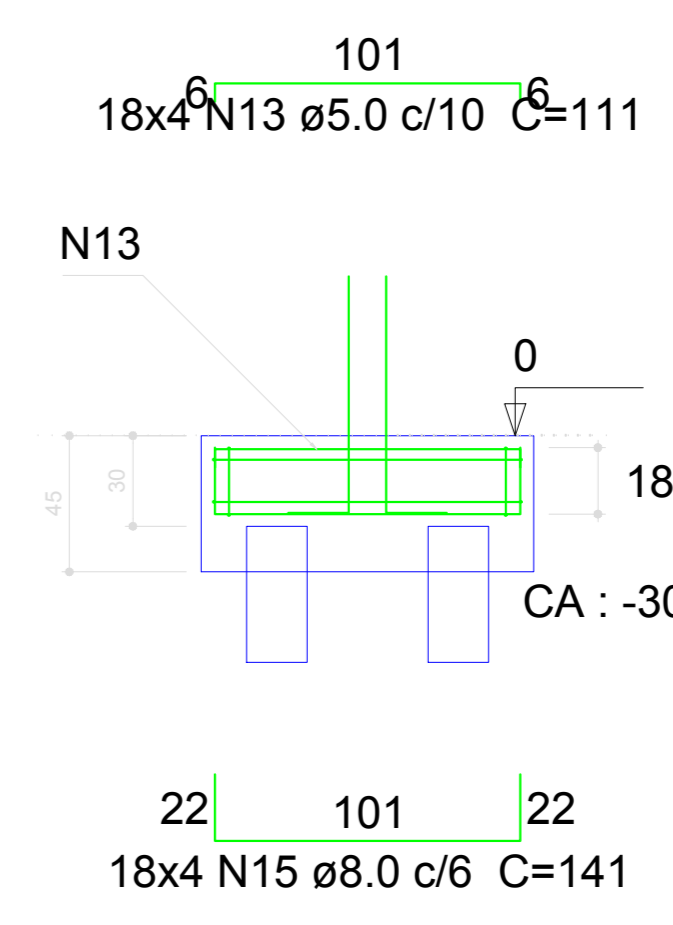

Luiz Carlos Schmulder  
PREFEITO

Antony N. Fernandes  
RESPONSÁVEL TÉCNICO



**PREFEITURA MUNICIPAL DE BOCAINA DO SUL**  
Reforma e Ampliação Creche Raulino Felipe dos Santos



Projeto estrutural, detalhamento dos blocos de coroamento  
Prefeito: Luiz Carlos Schmulder  
Responsável técnico: Eng. Antony N. Fernandes  
Escalas: Indicadas  
Prancha nº: 06/08