

1 PLANTA BAIXA - TERCEIRO PAVIMENTO
1 : 75

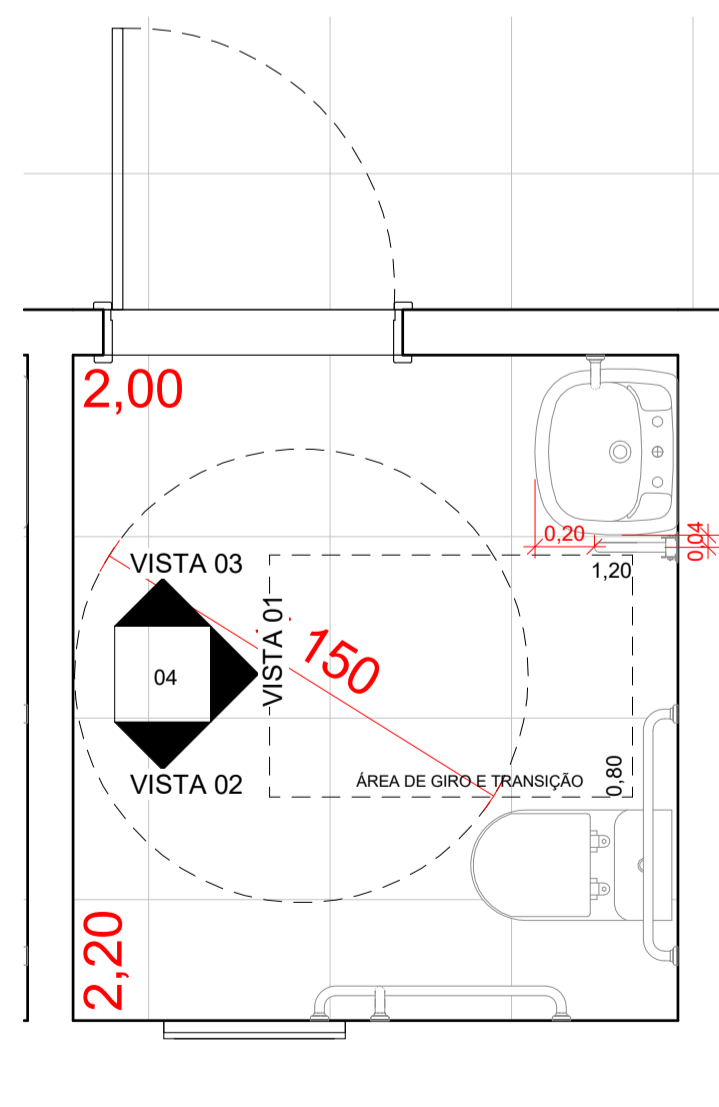

2 DETALHE 01
1 : 25

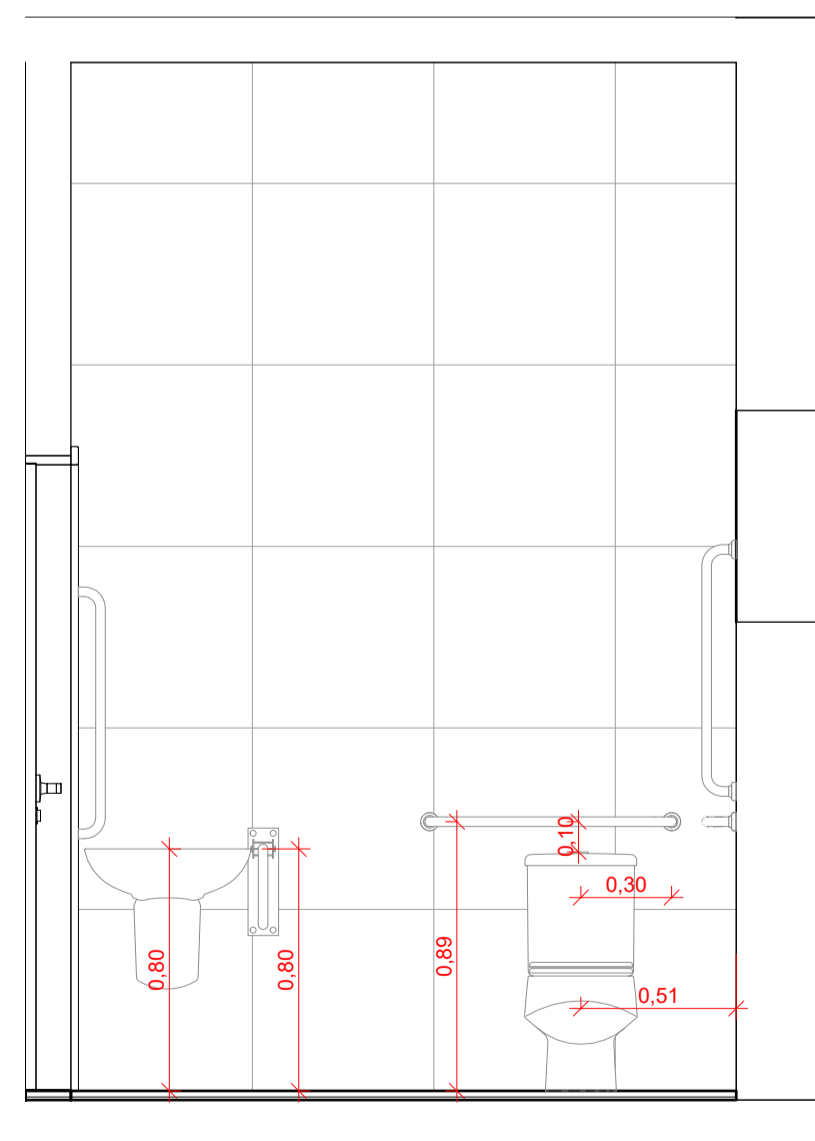

3 VISTA 01
1 : 25

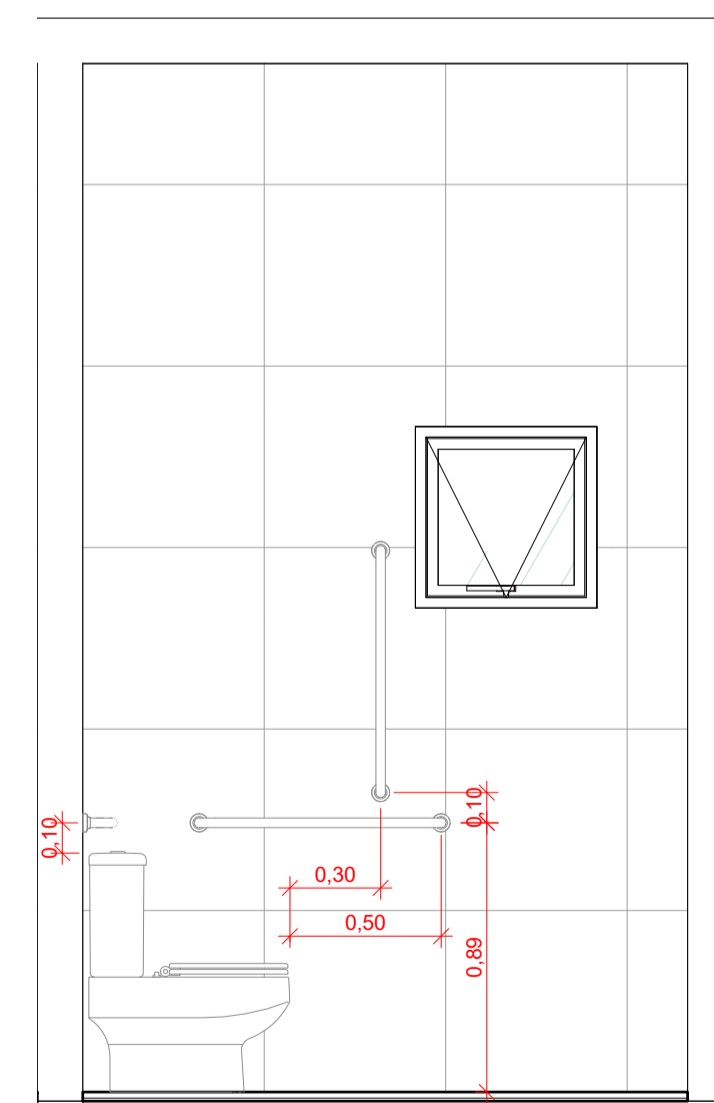

4 VISTA 02
1 : 25

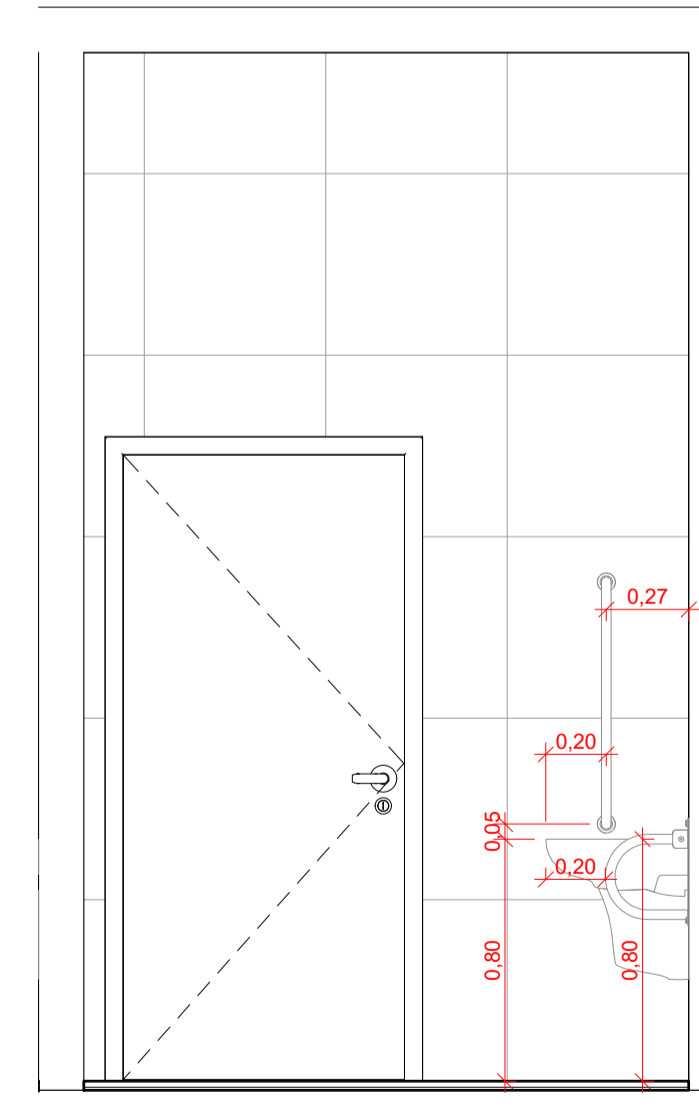

5 VISTA 03
1 : 25

AMURES ASSOCIAÇÃO DE MUNICÍPIOS DA REGIÃO SERRANA	
PREFEITURA MUNICIPAL DE BOCAINA DO SUL (SC)	
04	
ASSESSORIA TÉCNICA	OBRA:
PROJETO: James André Clauberg Eng. Civil - CREA 45.160-6	Reforma e Ampliação Secretaria de Saúde e Unidade Básica de Saúde
PREFEITO(A): João Eduardo Della Justina	Planta Baixa Terceiro Pavimento - Reforma Detalhe 01 Detalhe 05
DESENHO: Mariane de Moraes Mota	Área existente terceiro pavimento: 644,85m²
ESCALA: Como indicado	DATA: 01/10/2022